

Electricity and Magnetism

Reading Assignment: Read the entire chapter.

Homework: see the web site for homework.

<http://web.fccj.org/~smilczan/psc/homewkmid.html>

The forces of electricity and charge are important both in the macroscopic world (the world we live in,) and the microscopic world (the world of atoms and molecules). In our everyday lives know that we are turning chemical energy stored in coal to electrical energy (at the power plant just over the Dames point bridge) and we then turn the electrical energy to heat (thermal energy) and light (radiant energy). In the microscopic world, the atoms and molecules are held together by electrostatic attraction.

What is Charge? (The structure of the atom)

(Section 5.2)

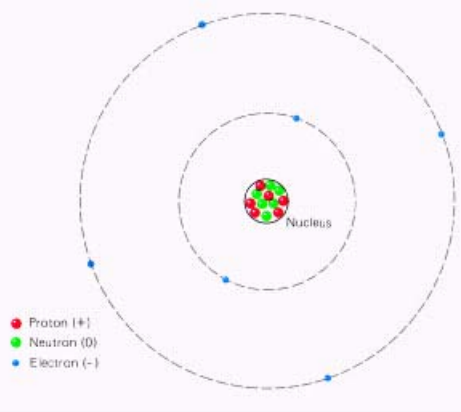

The atom is composed of sub-atomic particles called _____, _____ and _____. In a standard view of the atom, the protons and neutrons are in a small area in the center of the atom called the nucleus. The electrons circle the nucleus the same way the earth revolves around the sun. The nucleus is very small compared to the size of the atom. As an analogy, if the atom were the size of a baseball stadium, then the nucleus would be smaller than a baseball, perhaps closer to the size of a ping pong ball. You can imagine that most of atom is, in fact, empty space.

	mass (amu)	mass (kg)	relative charge	charge in coulombs
proton	1	1.67×10^{-27}	+1	1.67×10^{-19}
neutron	1	1.67×10^{-27}	0	0
electron	0.00054	9.11×10^{-31}	-1	-1.67×10^{-19}

Positive and Negative Charge

(Section 5.1)

Electric charge is a fundamental property of certain of the elementary particles of which all matter is composed. All electric charges are either _____ or _____. Like charges repel each other, unlike charges attract each other. Matter that has no overall charge is called neutral. In anything larger than an atom, this means that the number of protons and equals the number of electrons.

The unit of charge is the _____ (C) and the charge on the electron is -1.6×10^{-19} C. Since the smallest charges possible are that of the proton and the electron, all charges, of either sign, occur in multiples of $e = 1.6 \times 10^{-19}$ C.

Coulombs's Law

(Section 5-3)

Coulombs law involves the quantifying (putting numbers to) of the attraction of unlike charges and the repulsion of like charges. There are two aspects that should be obvious to us. First, the greater the charges, the greater the repulsion or attraction. If I am a proton, with a 1+ charge, a particle with a 2+ charge should be twice as repulsive to be as a particle with a 1+ charge. The second aspect is that the attraction/repulsion decreases with distance. If I am a proton, with a 1+ charge, I will be more repulsed by a particle with a 1+ charge right next to me than a particle with a 1+ charge 100 yards away.

The results of experimentation show that this effect can be quantified with the following equation:

$$F = K \frac{Q_1 Q_2}{R^2} = 9 \times 10^9 \frac{Q_1 Q_2}{R^2}$$

where Q_1 and Q_2 are the charges, K is a constant (9×10^9 N m²/C²) and r is the distance between the charges in meters.

Shouldn't the protons in a nucleus repel each other and fly apart?

The helium nucleus contains two protons. They repel each other. Why doesn't the helium nucleus break apart? The answer is very unsatisfying. There is another force called the "binding force" or "nuclear force" that holds the nucleus together. One can imagine that this is a very strong force and it is the energy from this force that we tap in to in nuclear reactions.

On the other hand, the electron is held together with the protons in the nucleus by the electrostatic force. The force of gravity between the masses of the nucleus and the electron is negligible compared to the electrostatic force in the atom.

Force on an uncharged object.

Surely you have noticed that static electricity can cause things to stick together. The explanation for this is a movement of electrons from one thing to another. Allow me to use a comb and a piece of paper as an example.

It is fairly dry today. As I comb my hair, the rubber comb picks up electrons from my hair. This gives the comb a negative charge and my hair a positive charge. Unlike the lady shown in the illustration below, my hair did not stick out too badly. Notice how

there was no overall change in the number of TOTAL protons and electrons. While I was in the bathroom I grabbed a small bit of toilet paper. As I brought the comb toward the paper, the paper jumped up and stuck to it.

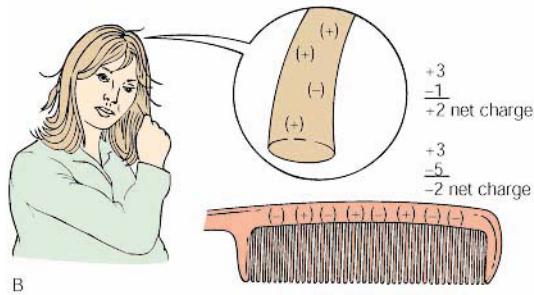
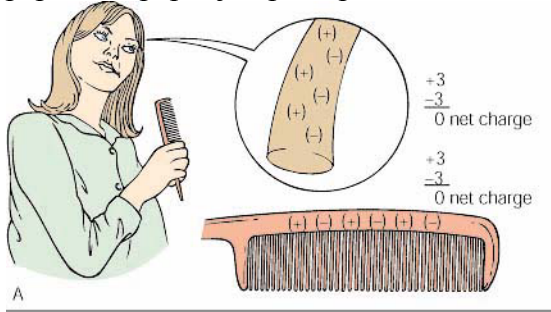

While I was in the bathroom I grabbed a small bit of toilet paper. As I brought the comb toward the paper, the paper jumped up and stuck to it. Why? The negative charges on the comb repelled the electrons in the paper. This left the positive charges near the comb. The negative comb and the positive side of the paper attracted each other and the paper stuck to the comb

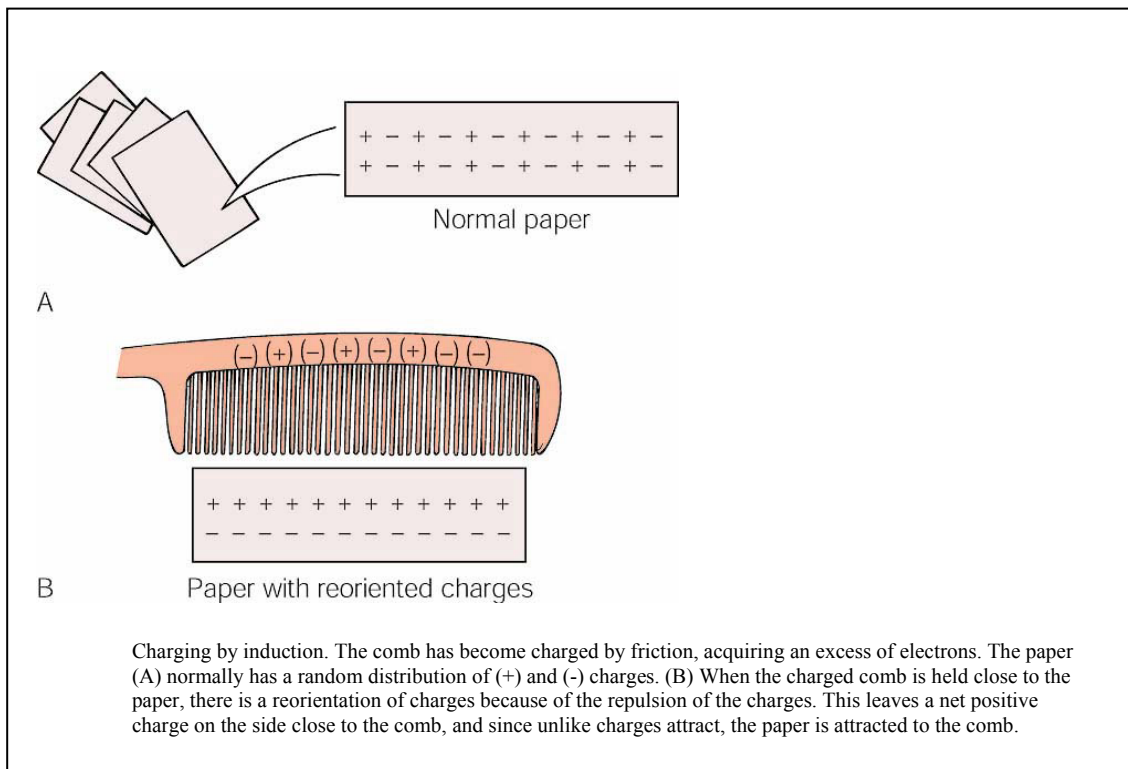

Charging by induction. The comb has become charged by friction, acquiring an excess of electrons. The paper (A) normally has a random distribution of (+) and (-) charges. (B) When the charged comb is held close to the paper, there is a reorientation of charges because of the repulsion of the charges. This leaves a net positive charge on the side close to the comb, and since unlike charges attract, the paper is attracted to the comb.

Please go to the following web site for more information on static electricity:

<http://207.10.97.102/physicszone/lesson/07elecst/static/triboele.htm>



(You may wish to draw the character in various stages of his walk.)

Anyone who has ever felt the zap of an electric shock after walking across a carpet and then touching a metal doorknob has experienced that two objects rubbing together can create electrostatic charges.

As the neutrally charged person walks across the wool carpet, his leather-soled shoes have less desire for electrons than the wool carpet. As a result, electrons get stolen from the shoe by the carpet. With every step the person becomes more and more positively charged. That charge distributes itself over the body. When the positively charged person gets near the metal door he will actually attract charges from the door which jump in the form of a spark. Notice how only the negative charges (electrons) are free to move.

Please watch Animation 5.1: Charging by Conduction and Induction on your CD.

The first segment shows charging by _____. A conducting object with an excess of positive charge is placed in contact with another conductor that is originally neutral. Charges move from one conductor to the other until the average distribution of all the charges on the surfaces of the two objects is the same. The second segment shows charging by _____. A charged object is brought near a neutral conductor and the charges that already exist in the neutral object shift. The like charges migrate away from the conductor and opposite charges migrate toward the conductor. If the originally neutral object is separated into two parts, then each part has an equal but opposite charge.

The Ampere
(Section 5.8)

A flow of charge from one place to another is an _____ . We can see a current in a simple circuit using a battery as a electromotive source. In a battery, a chemical reaction is taking place that causes electrons to move. We then harness these electrons by forcing them to go through a wire.

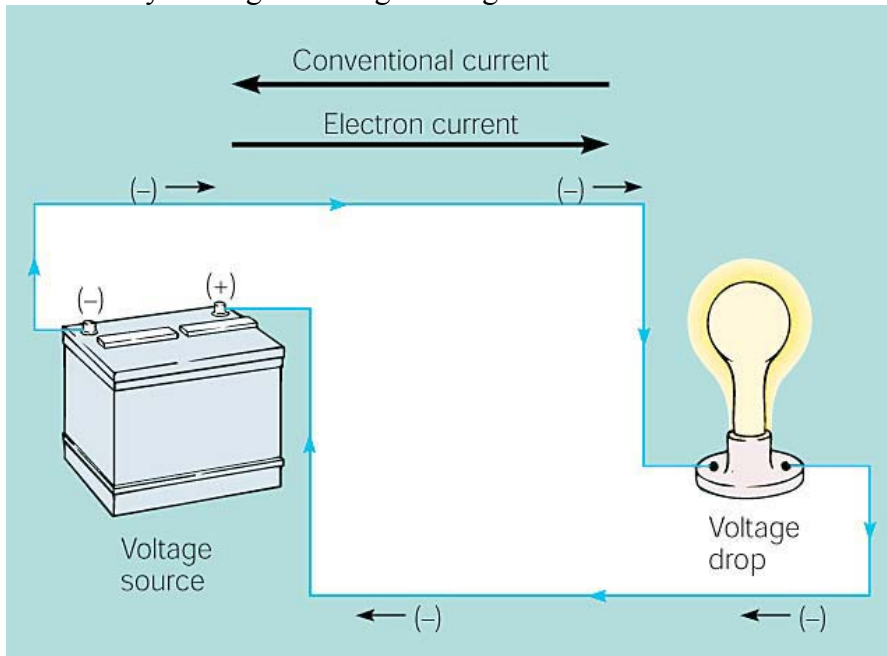

We can see the effects of this electron flow with the light bulb, which converts some of the energy of this movement to light. The light bulb also gets hot so it is converting some of the energy to heat. Light bulbs and heating elements are examples of resistors, they impede the flow of electrons. The flow of electrons is called **current** and is measured in amperes (A). An **ampere** is equal to a flow of 1 coulomb/second.

A conventional current describes positive charges moving from the positive terminal (+) to the negative terminal (-). You may see this convention in circuit diagrams in physics books. Chemists describe electron current as negative charges (-) moving from the negative terminal (-) to the positive terminal (+). This would seem to make more sense, as it is electrons that are moving. (sort of...)

Actually, individual electrons move very slowly. With a drift velocity of 0.01 cm/s, more than 5 hr would be required for an electron to travel 200 cm from a car battery to the brake light. What actually happens is that an electron “pushes” another electron, which “pushes” another electron and so on down the length of the wire. Therefore, it is the electric field, not the electrons, which moves at near the speed of light in an electric circuit.

There are four factors that influence the resistance of an electrical conductor. They are the length of the conductor, the cross-sectional area of the conductor, the material the conductor is made of, and the temperature of the conductor.

We have seen batteries run motors so we know they can do work. How much? The answer is it depends on the push from the battery. This push is called the electrical potential or **voltage** and is the electric potential energy per amount of charge. It is measured in voltage. 1 volt = J/C

The voltage of batteries set up in series is additive. To connect batteries in series one connects the positive terminal of one battery to the negative terminal of another. Two 1.5V batteries set up this way will have a combined voltage of 3.0 volts.

Ohm's Law

(Section 5.10)

In a circuit, we can imagine the greater the resistance (or impedance) to flow the lower the current (or flow). We can also imagine the greater the push (or voltage), the greater the current (or flow). Ohm's Law can summarize this:

$$I = \frac{V}{R} \text{ or } V = I \cdot R$$

where I is the current (in amperes), V is the voltage (in volts) and R is the resistance. Resistance is measured in ohms and is this unit is given the Greek letter omega.

$$1 \Omega = 1 \frac{V}{A}$$

Feel free to examine animation 5.2: Ohm's Law if you like.

Sample Problem

In our problem we can draw a circuit diagram with the following symbols.



If we have a circuit with a 4 Ohm resistor and a 12 volt battery, what is the current?

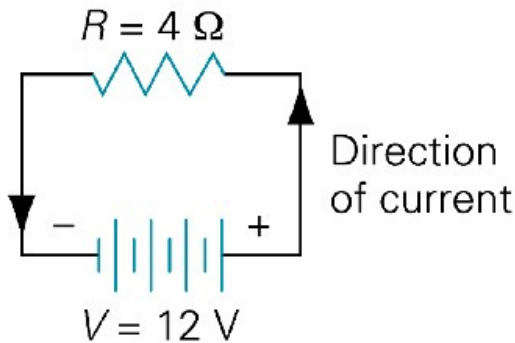

Electric Power

The power of an electric current is the rate at which work is being done. Electrical power is current times voltage.

$$P=I \times V \text{ or } P=IV$$

P is power, I is current and V is voltage. The unit of power is the *watt* (W)

Magnetism

(Section 5.12)

The subjects of magnetism and electricity developed almost independently of each other until 1820, when a Danish physicist named Hans Christian Oersted discovered in a classroom demonstration that an electric current affects a magnetic compass. He saw that magnetism was related to electricity. We will begin by looking at permanent magnets and then look at Oersted's experiment.

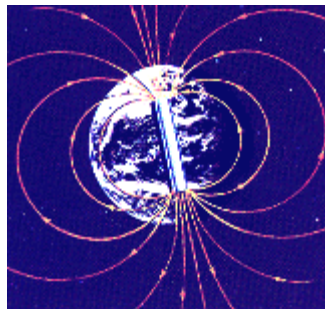

Magnets have a north and a south pole. Like magnetic poles repel each other and unlike poles attract each other. The names of the poles come from the fact that the earth has a magnetic field. The part of the magnet that will align toward the north pole of earth is called the north pole of the magnet.

Some atoms, depending on their electronic structure, act like magnets and have a north and south pole. In most matter, there is no alignment of the poles of the atoms. In a bar magnet, the atoms will line up. Sometimes this alignment can be achieved by simply

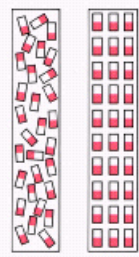

banging on a piece of iron. This can cause enough of the atoms to line up with the earth's magnetic field for the magnetic field of the iron to be measured.

The iron atoms in an unmagnetized iron bar are randomly oriented, whereas in a magnetized bar they are aligned with their north poles pointing in the same direction. The ability of iron atoms to remain aligned in this way is responsible for the magnetic properties of iron.

Oersted's Experiment

(Section 5.14)

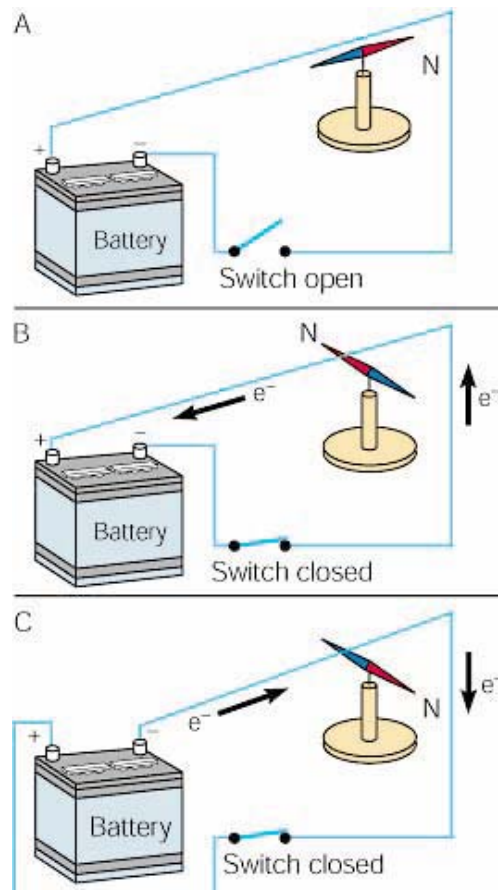

Oersted discovered that a compass needle below a wire (A) pointed north when there was not a current, (B) moved at right angles when a current flowed one way, and (C) moved at right angles in the opposite direction when the current was reversed.

The Right Hand Rule:

What we can determine from this is that an electrical current produces a magnetic field. A magnetic field surrounds the wire as shown below

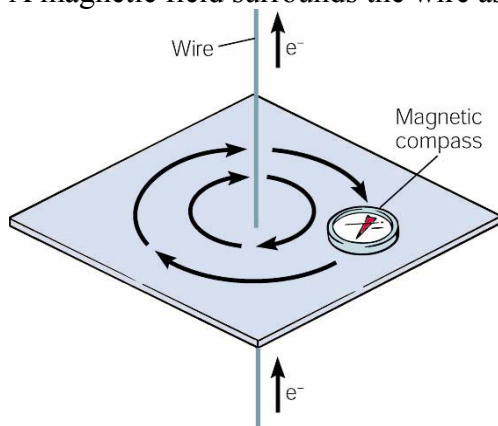

A magnetic compass shows the presence and direction of the magnetic field around a straight length of current-carrying wire.

This effect can be summarized by the right hand rule. This rule states that if you put the thumb of your right hand in the direction of the current, the magnetic field will wrap around the wire the same way your fingers will.

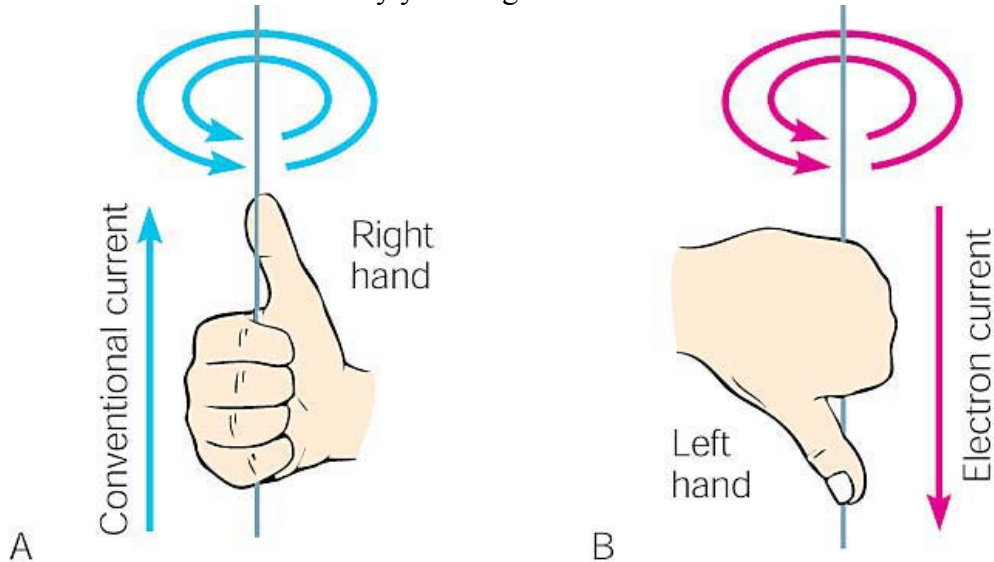

Use (A) a right-hand rule of thumb to determine the direction of a magnetic field around a conventional current. Remember that most people write current going from positive to negative. If your stubbornness requires you to think about electron flow, you will have to reverse everything and use the left-hand rule of thumb.

Electromagnets

(Section 5.15)

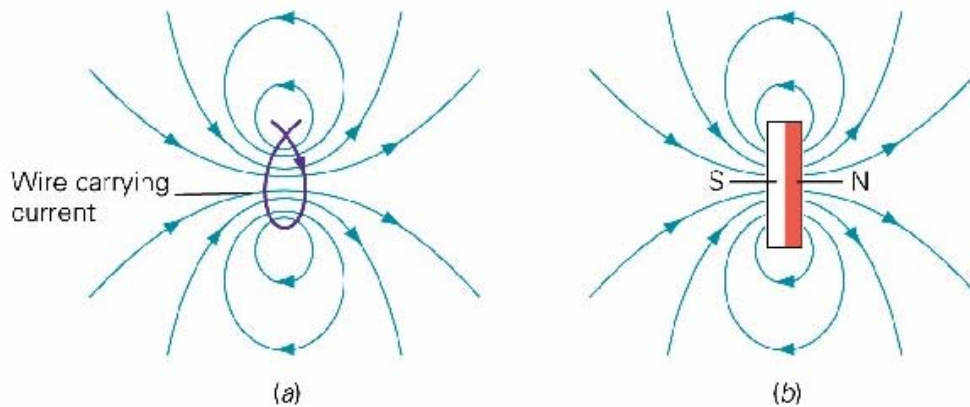

Forming a wire into a loop causes the magnetic field to pass through the loop in the same direction. Notice that all sides of the loop, by using the right hand rule, push the magnetic field the same direction. This gives one side of the loop a north pole and the other side a south pole. The magnetic field of the loop is the same of that as a bar magnet.

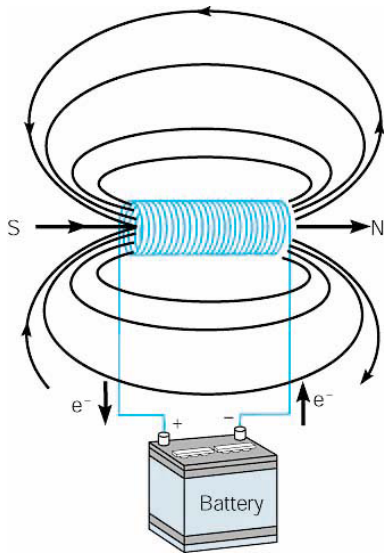

When a current is run through a cylindrical coil of wire, a solenoid, it produces a magnetic field like the magnetic field of a bar magnet.

Magnetic force and current.

Because a wire carrying a current away from you, represented by the black dot, has a magnetic field it will be affected by the magnetic field of a magnet. The yellow and red boxes represent the ends of the magnet. The field of the magnet is in green. The circular magnetic field of the wire is shown. Notice how at the top the fields are lined up and repelling and at the bottom the fields are opposite and attracting. The wire, if it can move, feels a force down called the Lorentz force. This force is perpendicular to both the magnetic field of the magnet and the current of the wire.

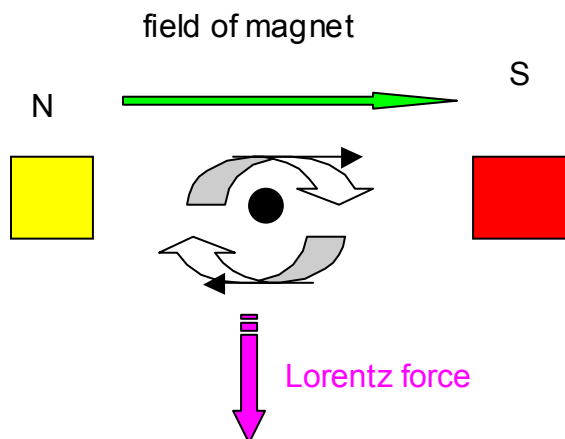

Motors

Please open this applet.

<http://webphysics.ph.msstate.edu/jc/library/20-3/index.html>

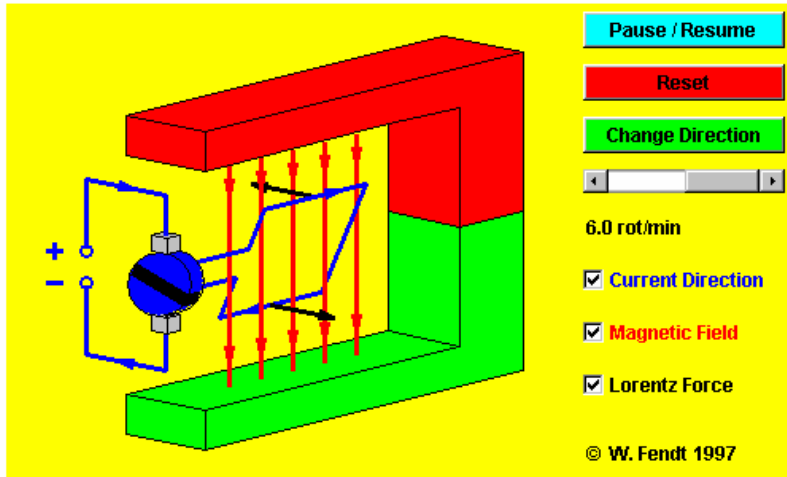

An **electric motor**, is a machine which converts electrical energy into mechanical (rotational or kinetic) energy. A current causes the coil to rotate mechanically. For this to occur

In the motor a current is passed through a loop, which is immersed in a magnetic field. A force exists on the top leg of the loop, which pushes the loop left, while a force on the bottom leg of the loop pushes the loop right. The net effect of these forces is to rotate the loop in the direction indicated. At some point, to keep the loop rotating it is necessary to switch the direction of the current. This is done on this applet when the loop is horizontal.

Induction

Electromagnetic induction refers to the production of a current in a wire when there is relative motion between the wire and a magnetic field. This connection was discovered by Faraday, who found that changing magnetic fields through loops of wire will cause currents to be induced.

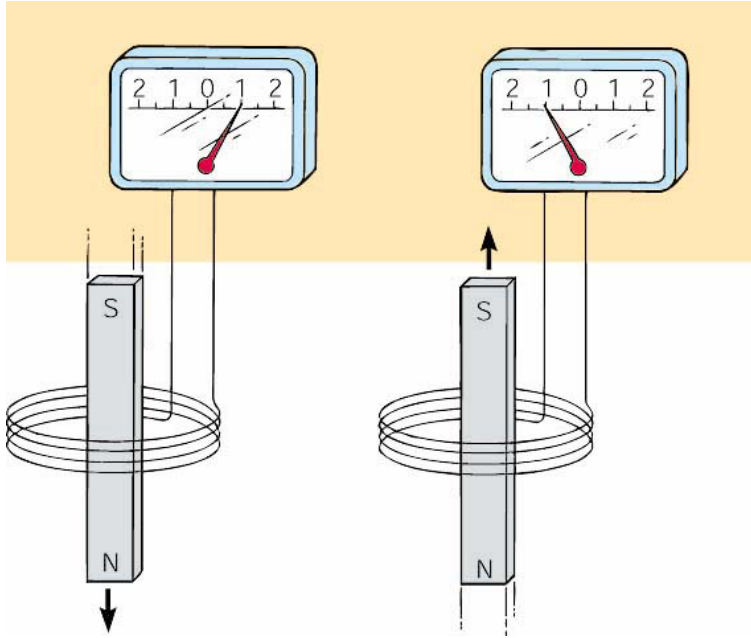

In the above picture, a current is induced in a coil of wire moved through a magnetic field. The direction of the current depends on the direction of motion. These induced currents only exist as long as the magnet is moving, and will die off when the magnet becomes stationary.

It is interesting to note that the current flows so as to create a magnetic field to oppose the change created by moving the bar magnet. This feature that the magnetic effects of the induced current are such as to oppose the external change is known as **Lenz's law**. The induction of currents from changing magnetic fields has a number of important applications, including, odiously, the electrical generator.

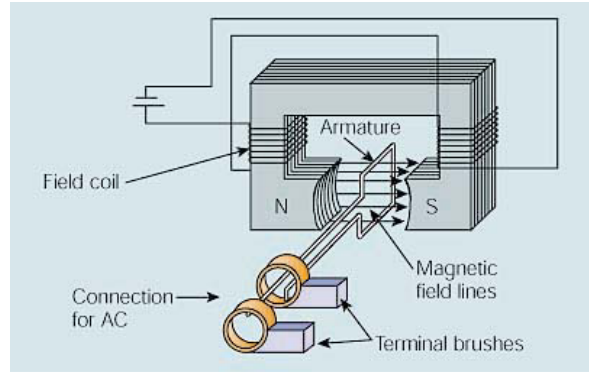

A

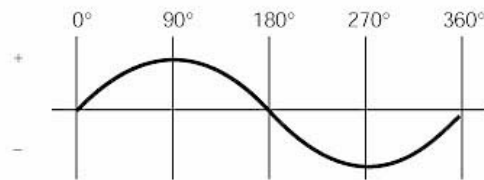

B

(A) Schematic of a simple alternator (ac generator) with one output loop. (B) Output of the single loop turning in a constant magnetic field, which alternates the induced current each half cycle.

Transformers

A transformers useful for changing the voltage of an alternating current circuit. In a **transformer** an alternating current in one coil of wire creates a changing magnetic field. This changing magnetic field induces an alternating current in another nearby coil. Depending on the ratio of turns of the coils, the induced current can have a voltage that is larger, smaller, or the same as that of the primary current.

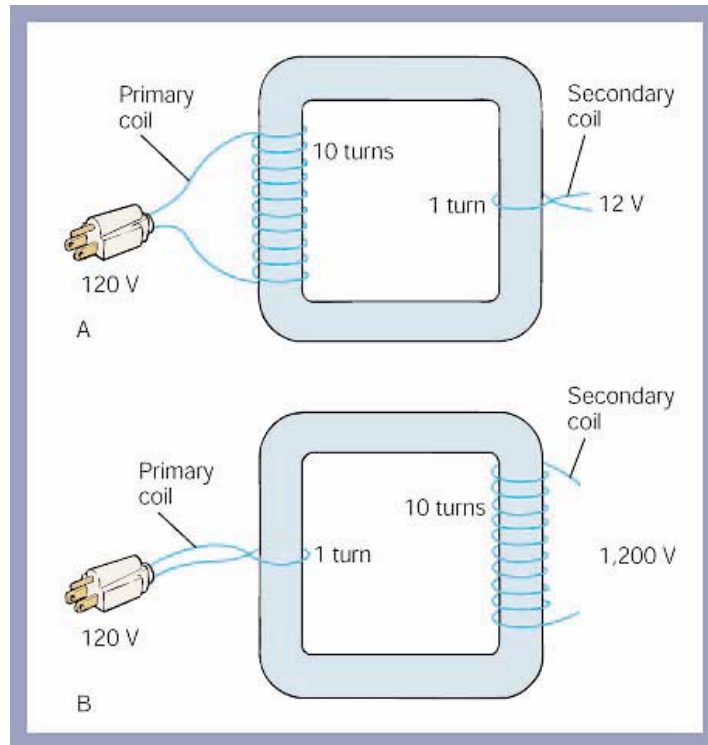

(A) This step-down transformer has 10 turns on the primary for each turn on the secondary and reduces the voltage from 120 V to 12 V. (B) This step-up transformer increases the voltage from 120 V to 1,200 V, since there are 10 turns on the secondary to each turn on the primary.